

# PS R2 Precision Balances

'Standard level' measurement under laboratory and slightly challenging industrial conditions



PS R2, d = 1 mg



PS R2, d = 10 mg



Single-point support for balance with Max > 6000 g



PS R2, d = 10 mg, Max > 6000 g



Large LCD display with text information section

## Functions

- |                |                  |                       |                                |                   |
|----------------|------------------|-----------------------|--------------------------------|-------------------|
| Parts counting | Percent weighing | Autotest              | Peak hold                      | Alibi memory      |
| Dosing         | Statistics       | Density determination | GLP procedures                 | Replaceable unit  |
| Checkweighing  | Animal weighing  | Under hook weighing   | Ambient conditions measurement | Multilingual menu |

## Features

### Ease of Use and Measurements Accuracy

Combination of weighing accuracy, high performance and robust design enables applying PS R2 balances in most of the laboratory and industrial solutions.

### Weighing Heavy Loads with the Maximum Accuracy

Due to an exceptionally wide range of capacities it is possible to work with samples of different weight, from few grams to even over one hundred kilograms.

### Perfect Readability and Clear Information Layout

Large, easy-to-read LCD display offers not only a clear presentation of the weighing result, but also enables displaying messages related to the drying process as well as pictograms of active functions and working modes.

### Quick Access to Selected Functions

Quick access keys located on the operation panel enable you to run a given function with just one click. You can assign some of the keys with a function of your choice.

### Automatic Adjustment

Internal adjustment system guarantees the highest accuracy and reliable measurements results.

### Data Management

PS R2 information system is based on operators, products, weighings and tares databases. All saved data can be analysed, exported, imported or exchanged between weighing instruments.

### ALIBI Memory

Internal ALIBI memory guarantees safety and automatic record of measurements copies, it also offers possibility to preview, copy and archive data.

## Technical Specifications

	PS 200/2000.R2	PS 210.R2	PS 360.R2
Maximum capacity [Max]	200 g / 2000 g	210 g	360 g
Minimum load	0.02 g	0.02 g	0.02 g
Readability [d]	0.001 g / 0,01 g	0.001 g	0.001 g
Verification scale interval [e]	0.01 g / 0.1 g	0.01 g	0.01 g
Tare range	-2000 g	-210 g	-360 g
Repeatability*	0.001 g / 0.01 g	0.001 g	0.001 g
Linearity	±0.002 g / ±0.02 g	±0.002 g	±0.002 g
Sensitivity temperature drift**	$2 \times 10^{-6} / ^\circ\text{C} \times R_t$	$2 \times 10^{-6} / ^\circ\text{C} \times R_t$	$2 \times 10^{-6} / ^\circ\text{C} \times R_t$
Minimum weight (U=1%, k=2)	0.1 g	0.1 g	0.1 g
Minimum weight (USP)	1 g	1 g	1 g
Stabilization time	2 s / 1.5 s	2 s	2 s
Adjustment	internal	internal	internal
Verification	Yes	Yes	Yes
OIML Class	II	II	II
Display	LCD (with backlight)	LCD (with backlight)	LCD (with backlight)
Keypad	14 keys	14 keys	14 keys
Protection class	IP 43	IP 43	IP 43
Databases	5	5	5
USB-A	1	1	1
USB-B	1	1	1
RS 232	2	2	2
Wireless connection (option)***	802.11 b/g/n	802.11 b/g/n	802.11 b/g/n
Power supply	12 ÷ 16 V DC	12 ÷ 16 V DC	12 ÷ 16 V DC
Power consumption	4 W	4 W	4 W
Operating temperature	+10 ÷ +40 °C	+10 ÷ +40 °C	+10 ÷ +40 °C
Atmospheric humidity****	40 ÷ 80 %	40 ÷ 80 %	40 ÷ 80 %
Transport and storage temperature	-20 ÷ +50 °C	-20 ÷ +50 °C	-20 ÷ +50 °C
Weighing pan dimensions	128 × 128 mm	128 × 128 mm	128 × 128 mm
Weighing device dimensions	333 × 208 × 100 mm	333 × 208 × 100 mm	333 × 208 × 100 mm
Net weight	3.9 kg	3.7 kg	3.7 kg
Gross weight	5.5 kg	5.3 kg	5.3 kg
Packaging dimensions	470 × 380 × 336 mm	470 × 380 × 336 mm	470 × 380 × 336 mm

Rt net weight

\* repeatability is expressed as a standard deviation from 10 weighing cycles

\*\* parameter determined in the following temperature range: +15 ÷ +35 °C

\*\*\* optional solution on purchase order

\*\*\*\* non-condensing conditions

In accordance with type approval, the balance parameters are maintained in temperature range: +15 ÷ +35 °C.

	PS 600.R2	PS 750.R2	PS 1000.R2
Maximum capacity [Max]	600 g	750 g	1000 g
Minimum load	0.02 g	0.02 g	0.02 g
Readability [d]	0.001 g	0.001 g	0.001 g
Verification scale interval [e]	0.01 g	0.01 g	0.01 g
Tare range	-600 g	-750 g	-1000 g
Repeatability*	0.0015 g	0.0015 g	0.0015 g
Linearity	±0.003 g	±0.003 g	±0.003 g
Sensitivity temperature drift**	$2 \times 10^{-6} / ^\circ\text{C} \times R_t$	$2 \times 10^{-6} / ^\circ\text{C} \times R_t$	$2 \times 10^{-6} / ^\circ\text{C} \times R_t$
Minimum weight (U=1%, k=2)	0.1 g	0.1 g	0.1 g
Minimum weight (USP)	1 g	1 g	1 g
Stabilization time	2 s	2 s	2 s
Adjustment	internal	internal	internal
Verification	Yes	Yes	Yes
OIML Class	II	II	II
Display	LCD (with backlight)	LCD (with backlight)	LCD (with backlight)
Keypad	14 keys	14 keys	14 keys
Protection class	IP 43	IP 43	IP 43
Databases	5	5	5
USB-A	1	1	1
USB-B	1	1	1
RS 232	2	2	2
Wireless connection (option)***	802.11 b/g/n	802.11 b/g/n	802.11 b/g/n
Power supply	12 ÷ 16 V DC	12 ÷ 16 V DC	12 ÷ 16 V DC
Power consumption	4 W	4 W	4 W
Operating temperature	+10 ÷ +40 °C	+10 ÷ +40 °C	+10 ÷ +40 °C
Atmospheric humidity****	40 ÷ 80 %	40 ÷ 80 %	40 ÷ 80 %
Transport and storage temperature	-20 ÷ +50 °C	-20 ÷ +50 °C	-20 ÷ +50 °C
Weighing pan dimensions	128 × 128 mm	128 × 128 mm	128 × 128 mm
Weighing device dimensions	333 × 206 × 100 mm	333 × 206 × 100 mm	333 × 206 × 100 mm
Net weight	3.9 kg	3.9 kg	3.9 kg
Gross weight	5.5 kg	5.5 kg	5.5 kg
Packaging dimensions	470 × 380 × 336 mm	470 × 380 × 336 mm	470 × 380 × 336 mm

Rt net weight

\* repeatability is expressed as a standard deviation from 10 weighing cycles

\*\* parameter determined in the following temperature range: +15 ÷ +35 °C

\*\*\* optional solution on purchase order

\*\*\*\* non-condensing conditions

In accordance with type approval, the balance parameters are maintained in temperature range: +15 ÷ +35 °C.

	PS 1200.R2	PS 2100.R2	PS 3500.R2
Maximum capacity [Max]	1200 g	2100 g	3500 g
Minimum load	0.5 g	0.5 g	0.5 g
Readability [d]	0.01 g	0.01 g	0.01 g
Verification scale interval [e]	0.1 g	0.1 g	0.1 g
Tare range	-1200 g	-2100 g	-3500 g
Repeatability*	0.01 g	0.01 g	0.01 g
Linearity	±0.02 g	±0.02 g	±0.02 g
Sensitivity temperature drift**	$2 \times 10^{-6} / ^\circ\text{C} \times R_t$	$2 \times 10^{-6} / ^\circ\text{C} \times R_t$	$2 \times 10^{-6} / ^\circ\text{C} \times R_t$
Minimum weight (U=1%, k=2)	1 g	1 g	1 g
Minimum weight (USP)	10 g	10 g	10 g
Stabilization time	1.5 s	1.5 s	1.5 s
Adjustment	internal	internal	internal
Verification	Yes	Yes	Yes
OIML Class	II	II	II
Display	LCD (with backlight)	LCD (with backlight)	LCD (with backlight)
Keypad	14 keys	14 keys	14 keys
Protection class	IP 43	IP 43	IP 43
Databases	5	5	5
USB-A	1	1	1
USB-B	1	1	1
RS 232	2	2	2
Wireless connection (option)***	802.11 b/g/n	802.11 b/g/n	802.11 b/g/n
Power supply	12 ÷ 16 V DC	12 ÷ 16 V DC	12 ÷ 16 V DC
Power consumption	4 W	4 W	4 W
Operating temperature	+10 ÷ +40 °C	+10 ÷ +40 °C	+10 ÷ +40 °C
Atmospheric humidity****	40 ÷ 80%	40 ÷ 80%	40 ÷ 80%
Transport and storage temperature	-20 ÷ +50 °C	-20 ÷ +50 °C	-20 ÷ +50 °C
Weighing pan dimensions	195 × 195 mm	195 × 195 mm	195 × 195 mm
Weighing device dimensions	333 × 206 × 100 mm	333 × 206 × 100 mm	333 × 206 × 100 mm
Net weight	4.3 kg	4.3 kg	4.5 kg
Gross weight	5.8 kg	5.8 kg	6 kg
Packaging dimensions	470 × 380 × 336 mm	470 × 380 × 336 mm	470 × 380 × 336 mm

Rt net weight

\* repeatability is expressed as a standard deviation from 10 weighing cycles

\*\* parameter determined in the following temperature range: +15 ÷ +35 °C

\*\*\* optional solution on purchase order

\*\*\*\* non-condensing conditions

In accordance with type approval, the balance parameters are maintained in temperature range: +15 ÷ +35 °C.

	PS 4500.R2	PS 6000.R2	PS 6001.R2
Maximum capacity [Max]	4500 g	6000 g	6000 g
Minimum load	0.5 g	0.5 g	0.5 g
Readability [d]	0.01 g	0.01 g	0.01 g
Verification scale interval [e]	0.1 g	0.1 g	0.1 g
Tare range	-4500 g	-6000 g	-6000 g
Repeatability*	0.01 g	0.015 g	0.1 g
Linearity	±0.02 g	±0.03 g	±0.1 g
Sensitivity temperature drift**	$2 \times 10^{-6} / ^\circ\text{C} \times R_t$	$2 \times 10^{-6} / ^\circ\text{C} \times R_t$	$2 \times 10^{-6} / ^\circ\text{C} \times R_t$
Minimum weight (U=1%, k=2)	1 g	1 g	1 g
Minimum weight (USP)	10 g	10 g	10 g
Stabilization time	1.5 s	1.5 s	1.5 s
Adjustment	internal	internal	internal
Verification	Yes	Yes	Yes
OIML Class	II	II	II
Display	LCD (with backlight)	LCD (with backlight)	LCD (with backlight)
Keypad	14 keys	14 keys	14 keys
Protection class	IP 43	IP 43	IP 43
Databases	5	5	5
USB-A	1	1	1
USB-B	1	1	1
RS 232	2	2	2
Wireless connection (option)***	802.11 b/g/n	802.11 b/g/n	802.11 b/g/n
Power supply	12 ÷ 16 V DC	12 ÷ 16 V DC	12 ÷ 16 V DC
Power consumption	4 W	4 W	4 W
Operating temperature	+10 ÷ +40 °C	+10 ÷ +40 °C	+10 ÷ +40 °C
Atmospheric humidity****	40 ÷ 80%	40 ÷ 80%	40 ÷ 80%
Transport and storage temperature	-20 ÷ +50 °C	-20 ÷ +50 °C	-20 ÷ +50 °C
Weighing pan dimensions	195 × 195 mm	195 × 195 mm	195 × 195 mm
Weighing device dimensions	333 × 206 × 100 mm	333 × 206 × 100 mm	333 × 206 × 100 mm
Net weight	4.5 kg	4.8 kg	4.8 kg
Gross weight	6 kg	6.4 kg	6.4 kg
Packaging dimensions	470 × 380 × 336 mm	470 × 380 × 336 mm	470 × 380 × 336 mm

Rt net weight

\* repeatability is expressed as a standard deviation from 10 weighing cycles

\*\* parameter determined in the following temperature range: +15 ÷ +35 °C

\*\*\* optional solution on purchase order

\*\*\*\* non-condensing conditions

In accordance with type approval, the balance parameters are maintained in temperature range: +15 ÷ +35 °C.

	PS 6100.R2	PS 8100.R2	PS 10100.R2
Maximum capacity [Max]	6100 g	8100 g	10100 g
Minimum load	0.5 g	0.5 g	0.5 g
Readability [d]	0.01 g	0.01 g	0.01 g
Verification scale interval [e]	—	—	—
Tare range	-6100 g	-8100 g	-10100 g
Repeatability*	0.01g	0.012 g	0.015 g
Linearity	±0.03 g	±0.03 g	±0.03 g
Sensitivity temperature drift**	$2 \times 10^{-6} / ^\circ\text{C} \times R_t$	$2 \times 10^{-6} / ^\circ\text{C} \times R_t$	$2 \times 10^{-6} / ^\circ\text{C} \times R_t$
Minimum weight (U=1%, k=2)	1 g	1 g	1 g
Minimum weight (USP)	10 g	10 g	10 g
Stabilization time	1.5 s	1.5 s	1.5 s
Adjustment	internal	internal	internal
Verification	—	—	—
OIML Class	—	—	—
Display	LCD (with backlight)	LCD (with backlight)	LCD (with backlight)
Keypad	14 keys	14 keys	14 keys
Protection class	IP 43	IP 43	IP 43
Databases	5	5	5
USB-A	1	1	1
USB-B	1	1	1
RS 232	2	2	2
Wireless connection (option)***	802.11 b/g/n	802.11 b/g/n	802.11 b/g/n
Power supply	12 ÷ 16 V DC	12 ÷ 16 V DC	12 ÷ 16 V DC
Power consumption	4 W	4 W	4 W
Operating temperature	+10 ÷ +40 °C	+10 ÷ +40 °C	+10 ÷ +40 °C
Atmospheric humidity****	40 ÷ 80%	40 ÷ 80%	40 ÷ 80%
Transport and storage temperature	-20 ÷ +50 °C	-20 ÷ +50 °C	-20 ÷ +50 °C
Weighing pan dimensions	195 × 195 mm	195 × 195 mm	195 × 195 mm
Weighing device dimensions	333 × 206 × 107 mm	333 × 206 × 107 mm	333 × 206 × 107 mm
Net weight	5.7 kg	5.7 kg	5.7 kg
Gross weight	7.3 kg	7.3 kg	7.3 kg
Packaging dimensions	470 × 380 × 336 mm	470 × 380 × 336 mm	470 × 380 × 336 mm

Rt net weight

\* repeatability is expressed as a standard deviation from 10 weighing cycles

\*\* parameter determined in the following temperature range: +15 ÷ +35 °C

\*\*\* optional solution on purchase order

\*\*\*\* non-condensing conditions

In accordance with type approval, the balance parameters are maintained in temperature range: +15 ÷ +35 °C.

## Dimensions

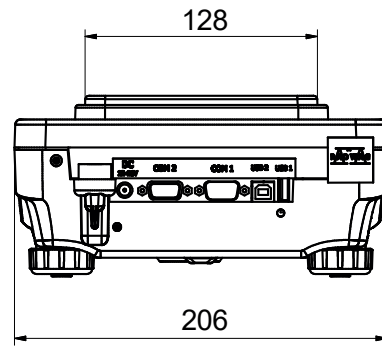
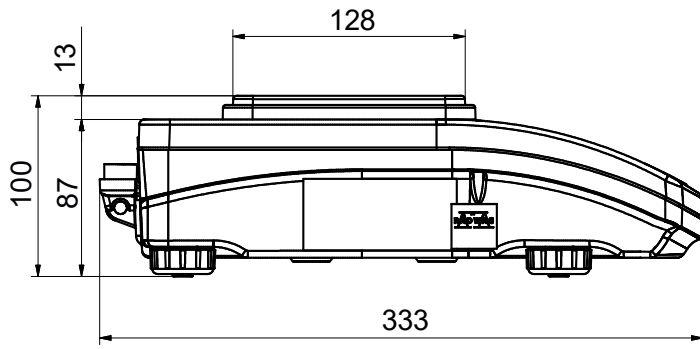

PS R2, d = 1mg

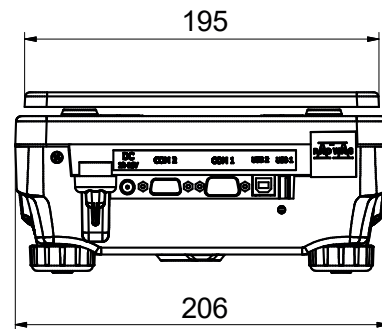
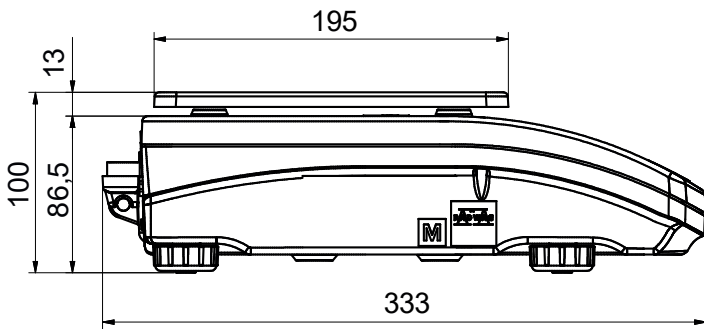

PS R2, d = 10 mg

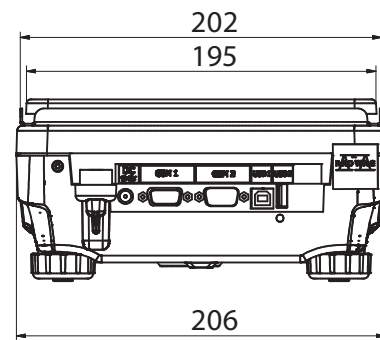
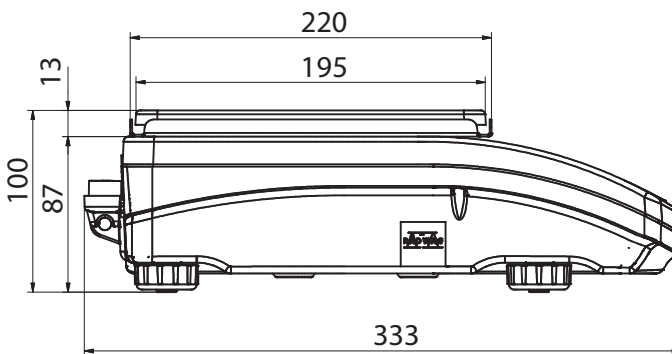

PS 6000.R2, PS 6001.R2

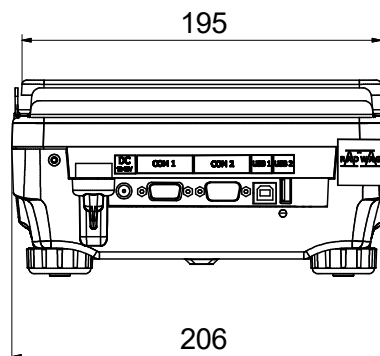
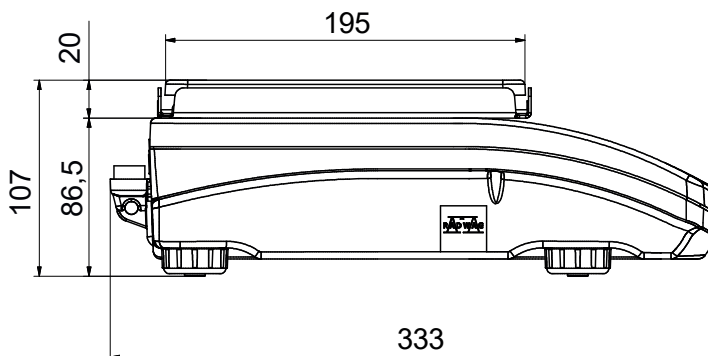

PS R2, d = 10 mg, Max > 6000 g

## Accessories

---

### Weighing Tables

- granite antivibration table
- antivibration tables for laboratory balances

### Professional Weighing

- KIT 195 density determination kit
- KIT 128 density determination kit
- under-hook weighing rack

### Peripheral Devices

- Epson dot matrix printer
- barcode scanners
- WD-6 LCD display

### Cables, Converters

- P0108: RS 232 cable (balance-computer)
- P0151: RS 232 cable (balance - Epson printer)
- USB cable type A-B
- AP2-1 power loop output

### Electrical accessories

- ZR-02 power supply with battery

### Draft Shields and Anti-Draft Chambers

- draft shield with a weighing pan 128 x 128 mm
- anti-draft chamber with a weighing pan 128 x 128 mm

### Remaining Accessories

- suitcase for PS.3Y

## Dedicated Software

---

### LabView Driver

- operation of RADWAG balances in LabView environment

### R-LAB

- collecting measurements
- carrying out statistical analysis of measurements
- customized graphs and reports

### Alibi Reader

- readout of data saved to Alibi memory
- export of data saved to Alibi memory
- data filtering and reports generating
- saving ALIBI database to CSV file